

Part number

CKH 03 I



Bulkhead mounting housing, CKH series, with 1 lever, size "21.21"

Product description

Product type	Bulkhead mounting housing
Series	CKH
Closing type	with 1 lever
Size	size "21.21"

Technical data

IP degree of protection	IP44 (IP66/IP67/IP69 with CKRH 65/CKRH 65 D kits)
--------------------------------	---------------------------------------------------

Further technical details

Weight	10,00 g
Operating temperature range (min, max)	-40°C...+70°C

Material properties

Main material	Polyamide (PA)
Other materials	Lever: polypropylene (PP) Gasket: silicone rubber
Colour	RAL 7012 grey, RAL 5015 blue

General ordering information

EAN13 code	8015747272001
-------------------	---------------

Packaging Information

Packaging description	Plastic bag
Packaging quantity	1 Pcs
Packaging EAN code	8015747280228

Part number

CKH 03 I



Catalogue drawings

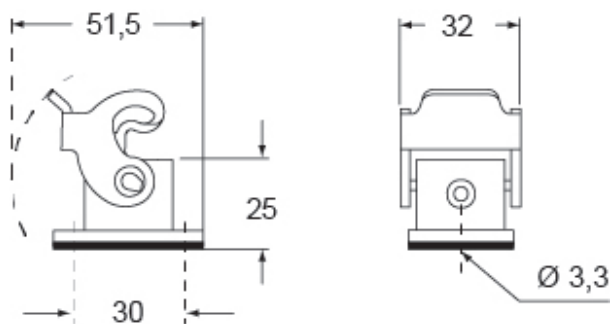

Catalogue drawings

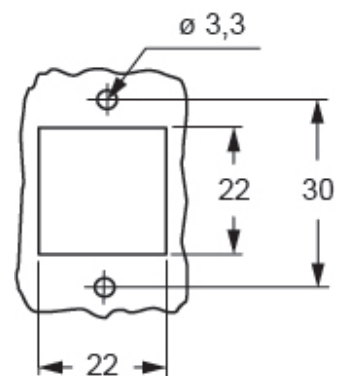

Notes

Dimensions shown in mm are not binding and may be changed without notice.