

7-16 DIN Female EZfit® for 7/8 in FXL-780, AVA5-50, and AVA5-50FX cable



## Product Classification

<b>Brand</b>	EZfit®
<b>Product Type</b>	Wireless and radiating connector

## General Specifications

<b>Interface</b>	7-16 DIN Female
<b>Body Style</b>	Straight
<b>Harmonized System (HS) Code</b>	854420 (Coaxial cable and other coaxial electric conductors)
<b>Mounting Angle</b>	Straight
<b>Ordering Note</b>	CommScope® non-standard product

## Electrical Specifications

<b>Connector Impedance</b>	50 ohm
<b>Operating Frequency Band</b>	0 – 5000 MHz
<b>Cable Impedance</b>	50 ohm
<b>3rd Order IMD, typical</b>	-116 dBm @ 1800 MHz
<b>3rd Order IMD Test Method</b>	Two +43 dBm carriers
<b>RF Operating Voltage, maximum (vrms)</b>	1415.00 V
<b>dc Test Voltage</b>	4000 V
<b>Outer Contact Resistance, maximum</b>	1.50 mOhm
<b>Inner Contact Resistance, maximum</b>	0.40 mOhm
<b>Insulation Resistance, minimum</b>	5000 MOhm
<b>Peak Power, maximum</b>	40.00 kW
<b>Insertion Loss, typical</b>	0.05 dB

# 78EZDF

## Outline Drawing

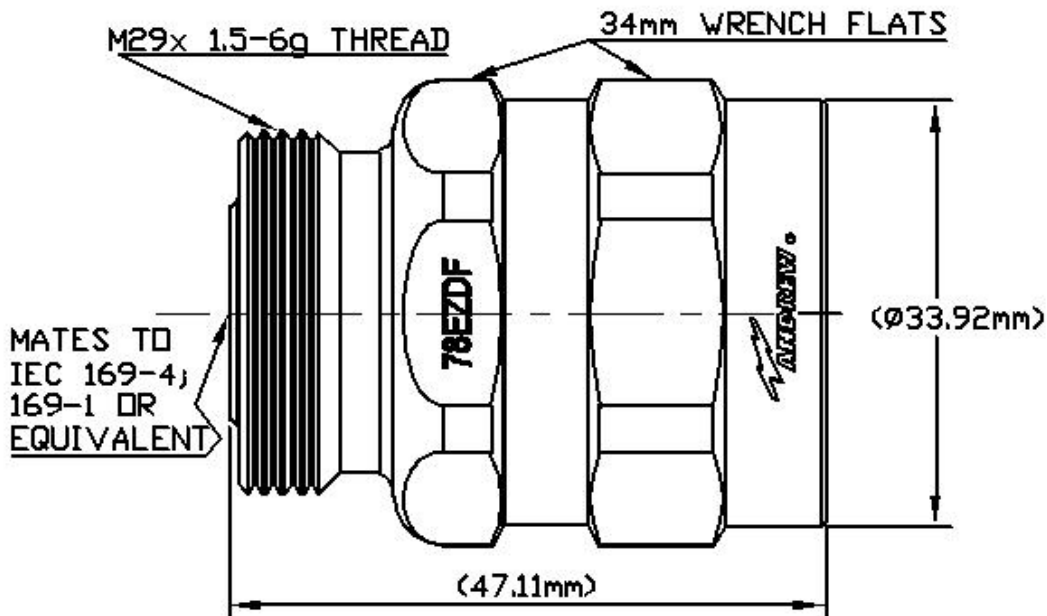

## Mechanical Specifications

<b>Outer Contact Attachment Method</b>	Clamp
<b>Inner Contact Attachment Method</b>	Captivated
<b>Outer Contact Plating</b>	Trimetal
<b>Inner Contact Plating</b>	Silver
<b>Attachment Durability</b>	25 cycles
<b>Interface Durability</b>	50 cycles
<b>Interface Durability Method</b>	IEC 61169-4:9.5
<b>Connector Retention Tensile Force</b>	1334 N   300 lbf
<b>Connector Retention Torque</b>	8.13 N-m   72.00 in lb
<b>Insertion Force</b>	200.17 N   45.00 lbf
<b>Insertion Force Method</b>	IEC 61169-1:15.2.4
<b>Pressurizable</b>	No

## Dimensions

<b>Nominal Size</b>	7/8 in
<b>Diameter</b>	37.00 mm   1.46 in
<b>Length</b>	47.90 mm   1.89 in
<b>Weight</b>	136.65 g   0.30 lb

## Environmental Specifications

<b>Operating Temperature</b>	-40 °C to +85 °C (-40 °F to +185 °F)
<b>Storage Temperature</b>	-55 °C to +85 °C (-67 °F to +185 °F)
<b>Immersion Depth</b>	1 m
<b>Immersion Test Mating</b>	Mated
<b>Immersion Test Method</b>	IEC 60529:2001, IP68
<b>Water Jetting Test Mating</b>	Mated
<b>Water Jetting Test Method</b>	IEC 60529:2001, IP66
<b>Moisture Resistance Test Method</b>	IEC 60529, IP68
<b>Mechanical Shock Test Method</b>	IEC 60068-2-27
<b>Vibration Test Method</b>	IEC 60068-2-6
<b>Corrosion Test Method</b>	IEC 60068-2-11, Test Condition Ka

## Standard Conditions

<b>Attenuation, Ambient Temperature</b>	20 °C   68 °F
<b>Average Power, Ambient Temperature</b>	40 °C   104 °F

## Return Loss/VSWR

Frequency Band	VSWR	Return Loss (dB)
50–1000 MHz	1.02	40.00
1000–1900 MHz	1.03	38.00
1900–2200 MHz	1.04	34.00
2200–2700 MHz	1.06	31.00
2700–3600 MHz	1.07	30.00
3600–5000 MHz	1.09	27.00

## Regulatory Compliance/Certifications

Agency	Classification
RoHS 2011/65/EU	Compliant by Exemption
ISO 9001:2015	Designed, manufactured and/or distributed under this quality management system
China RoHS SJ/T 11364-2014	Above Maximum Concentration Value (MCV)



## \* Footnotes

<b>Immersion Depth</b>	Immersion at specified depth for 24 hours
<b>Insertion Loss, typical</b>	$0.05\sqrt{\text{freq (GHz)}}$ (not applicable for elliptical waveguide)