

Part number

CZI 15 LS



Brief description:

bulkhead mounting housings with single lever, size "49.16", metal cover, metal version, IP65

Product description

Version	CZ levers, standard version
Series	Bulkhead mounting housings with 1 lever
Product type	with 1 lever
Variant	metal cover
Family	CZ - MZ enclosures
Size	size "49.16"

Technical data

Operating temperature range (min, max)	-40°C ... +125°C
Material	metal
IP degree of protection	IP65

Further technical details

Weight	121,00 g
---------------	----------

Approvals / Standards

Quality mark	 (type:4/4X/12),  , EAC
Conformity	CQC, CE

General ordering information

EAN13 code	8015747044073
Tariff number	85369095

Packaging Information

Packaging length	250,00 mm
Packaging height	145,00 mm
Packaging width	300,00 mm
Packaging weight	5,25 kg
Packaging volume	10,88 dm ³
Packaging description	Carton box
Packaging quantity	40 Pcs
Packaging EAN code	8015747127707
Sub-packaging weight	0,66 kg
Sub-packaging description	Plastic packaging
Sub-packaging quantity	5 Pcs
Sub-packaging EAN barcode	8015747127714

Part number

CZI 15 LS



Catalogue drawings

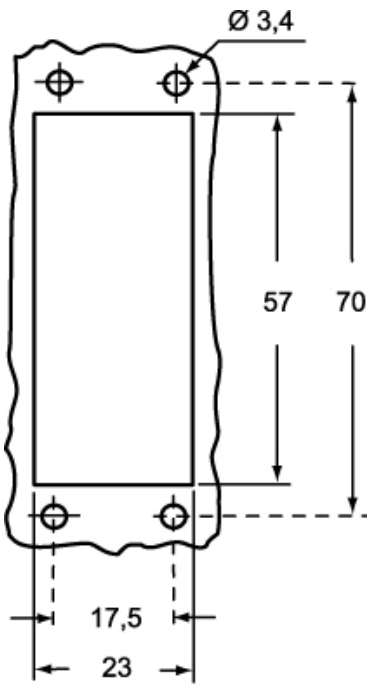

Catalogue drawings

CZI L

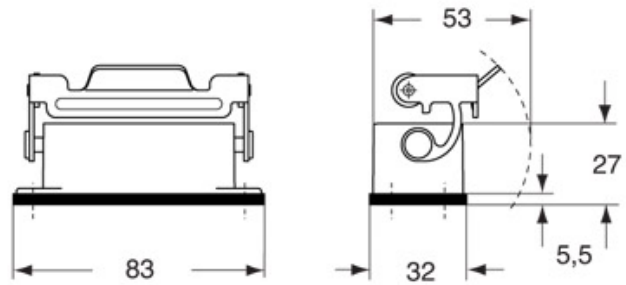

CZI LS

