

Part number

CZI 15 L



Brief description:

bulkhead mounting housings with single lever, size "49.16", metal version, IP66

Product description

Version	CZ levers, standard version
Series	Bulkhead mounting housings with 1 lever
Product type	with 1 lever
Family	CZ - MZ enclosures
Size	size "49.16"

Technical data

Operating temperature range (min, max)	-40°C ... +125°C
Material	metal
IP degree of protection	IP66 (and IP69K DIN 40050 - 9)

Further technical details

Weight	70,00 g
---------------	---------

Approvals / Standards

Quality mark	 (type:4/4X/12),  , EAC
Conformity	CQC, CE

General ordering information

EAN13 code	8015747044059
Tariff number	85369095

Packaging Information

Packaging length	160,00 mm
Packaging height	180,00 mm
Packaging width	270,00 mm
Packaging weight	3,11 kg
Packaging volume	7,78 dm ³
Packaging description	Carton box
Packaging quantity	40 Pcs
Packaging EAN code	8015747127660
Sub-packaging weight	0,39 kg
Sub-packaging description	Plastic packaging
Sub-packaging quantity	5 Pcs
Sub-packaging EAN barcode	8015747127677

Part number

CZI 15 L



Catalogue drawings

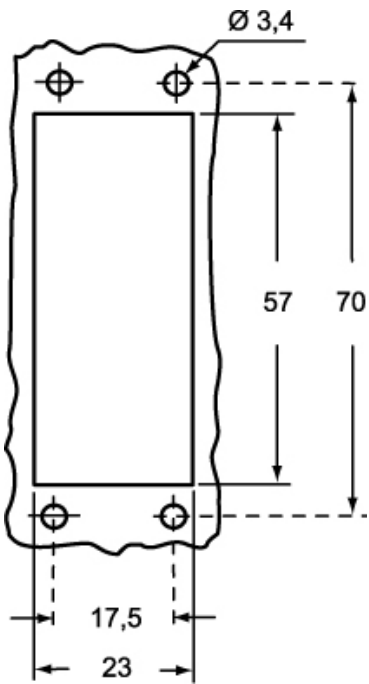

Catalogue drawings

CZI L

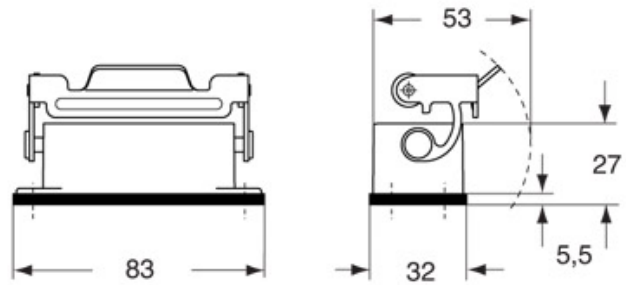

CZI LS

